



# INSTALLATION & USER'S GUIDE

RadiusCX Clutch Upgrade Kit  
For KTM/Husqvarna DDS clutches

Doc ID: 191-7911A

Revision: 052317

# TABLE OF CONTENTS

OVERVIEW .....	3
INSTALLATION TIPS .....	3
Tuning Note .....	4
TOOLS .....	4
INCLUDED PARTS .....	5
DISASSEMBLE THE CLUTCH .....	6
INSPECT THE DAMPERS .....	8
CLUTCH PACK INSTALLATION.....	9
PRESSURE PLATE INSTALLATION.....	12
SET THE INSTALLED GAP AND VERIFY BY CHECKING FREE PLAY GAIN .....	17
Step 1: Find the starting point.....	18
Step 2: Learn how to check Free Play Gain .....	19
Two Ways to Check for Free Play Gain .....	21
The Rubber Band Method .....	21
The Hand Method.....	24
Step 3: Break-in the new clutch.....	26
Step 4: Adjust the installed gap and Recheck Free Play Gain ...	28
FREE PLAY GAIN ADJUSTMENTS .....	30
MAINTENANCE .....	31
Disk inspection examples .....	33
TROUBLESHOOTING .....	34
Performance issues.....	34
Clutch noise.....	34
EXP TUNING OPTIONS .....	34
Changing the springs .....	35
Configuration chart.....	37
BUMP-STARTING THE BIKE .....	37
NEED ADDITIONAL HELP? .....	38

## OVERVIEW

This guide shows you how to replace your OE (Original Equipment) core clutch parts with your new Rekluse upgraded clutch parts. The following parts are replaced:

- Core EXP 3.0 Drive Plates
- OE Friction Disks

## INSTALLATION TIPS



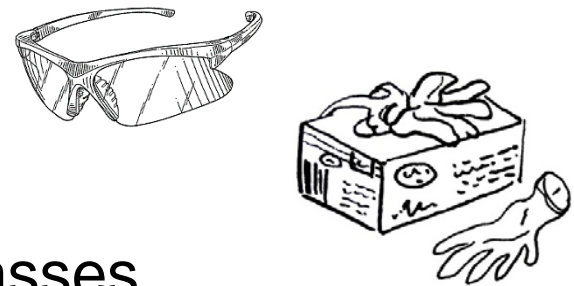



- Read the safety information sheet included with your kit.
- Protect eyes and skin – wear safety glasses and thin disposable work gloves.
- Read this entire document before performing any steps.
- Lay the bike on its left side when replacing the clutch. This makes the clutch work easier and eliminates the need to drain the oil.
- Use clean, quality JASO MA or JASO MA2 certified transmission oil for best performance.
- Bikes with taller gearing or modified engines with increased horsepower may require heavier wedges. These can be purchased separately from Rekluse.



## Tuning Note: (especially for 2-stroke owners):

- Once installed, if you desire your clutch to engage more aggressively, one option is to purchase the heavier Belleville spring from KTM (KTM calls it the “280” spring).
- Replacing this spring makes the clutch engagement more aggressive. However, this will increase the pull on the clutch lever. The spring comes stock on 2013 and newer Factory Edition 450SX-F bikes, 2014 and newer 450SX-F/XC-F bikes, 2017 and newer 450/500 EXC-F bikes.
- The part number is KTM Part #: 78932005000

## TOOLS

 4 mm	 8 mm		
4 mm Allen Wrench	8 mm Socket	Torque Wrench	T-25 Torx Bit
 Oil			
Oil	Calipers	Fluid Catch Container	

# INCLUDED PARTS

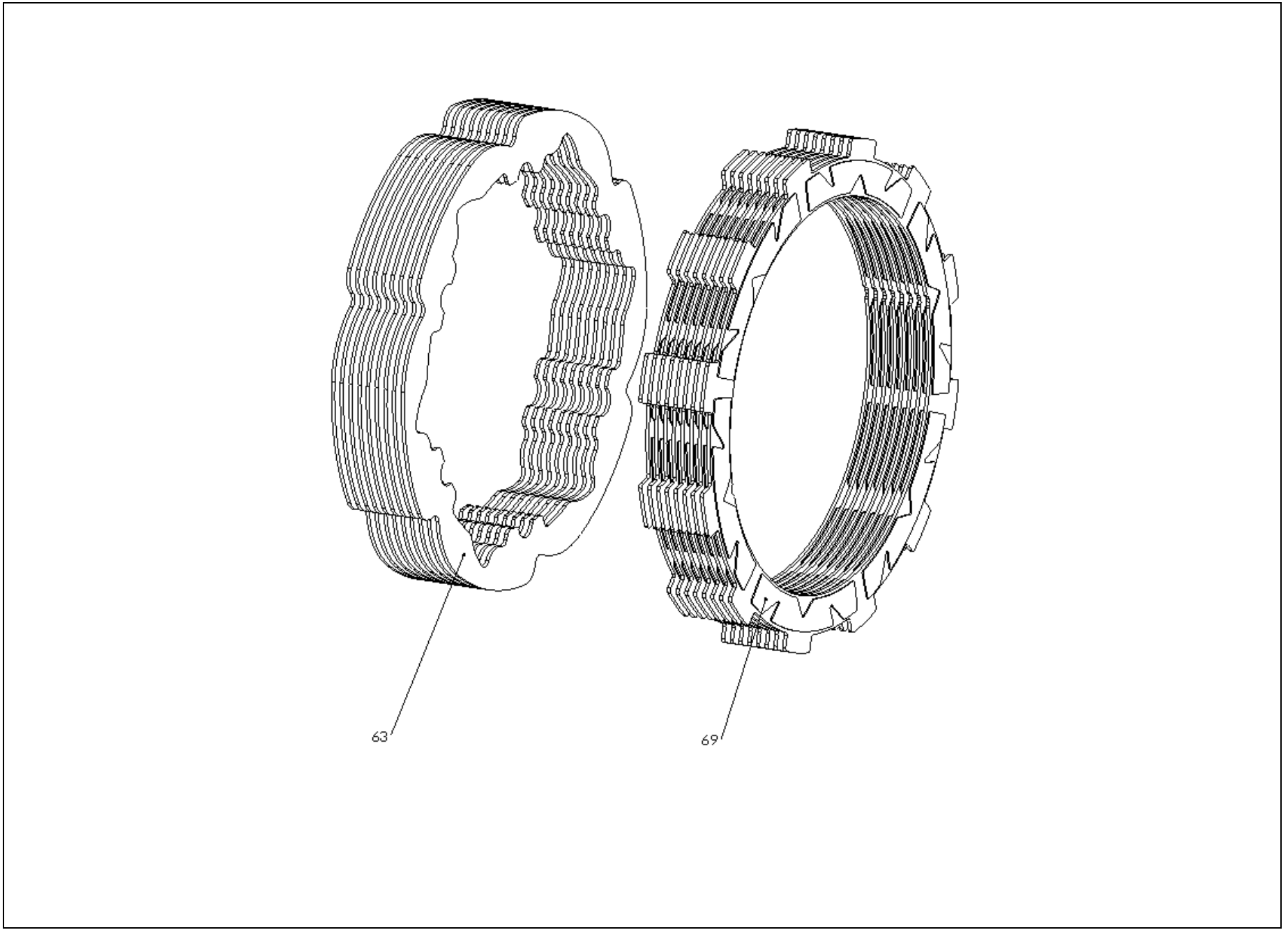

Item	Description	Qty.
63	TEC Steel Drive Plate	9
69	TorqDrive® Friction	8

Visit [www.rekluse.com/support](http://www.rekluse.com/support) for a full parts fiche illustration and part numbers.

# DISASSEMBLE THE CLUTCH

1. Turn the fuel petcock to “OFF” if applicable.

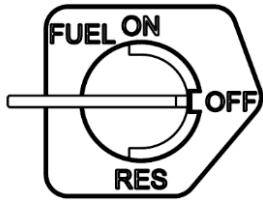

2. Lay the bike on its left side. Catch any fuel that might drain in a suitable container.



3. Use an 8 mm socket to remove the clutch cover.



8 mm

4. Use a T-25 Torx bit to remove the following parts. When removing the Belleville spring, make sure to note the orientation of the spring. See the following picture for reference.



T-25 Torx

- 6 pressure plate screws
- Pressure ring
- Belleville spring
- Slider ring
- Lining plate
- Core EXP 3.0 pressure plate
- Clutch pack

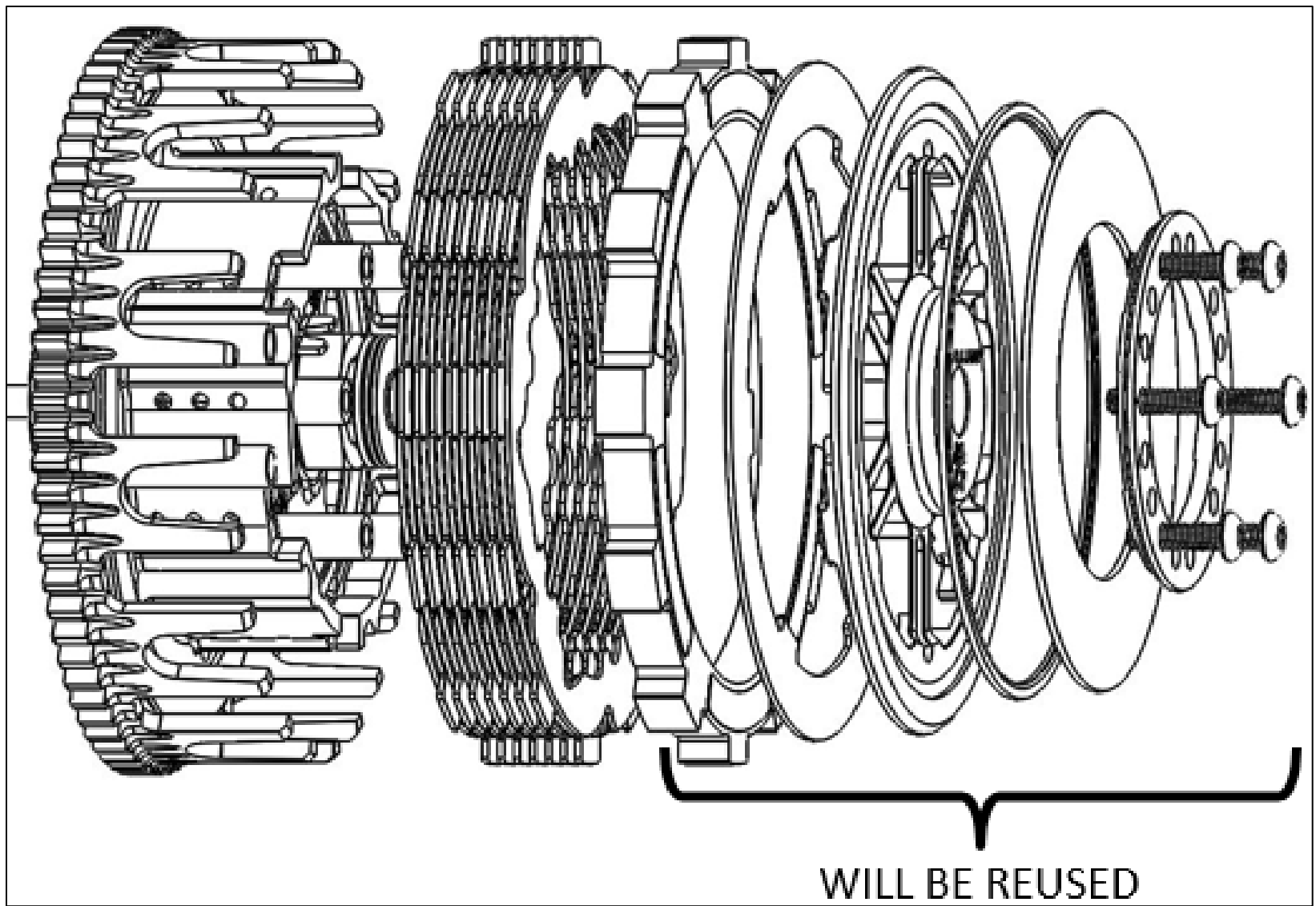

**⚠ CAUTION**

*Be careful that the drive pins do not fall into the engine while disassembling.*

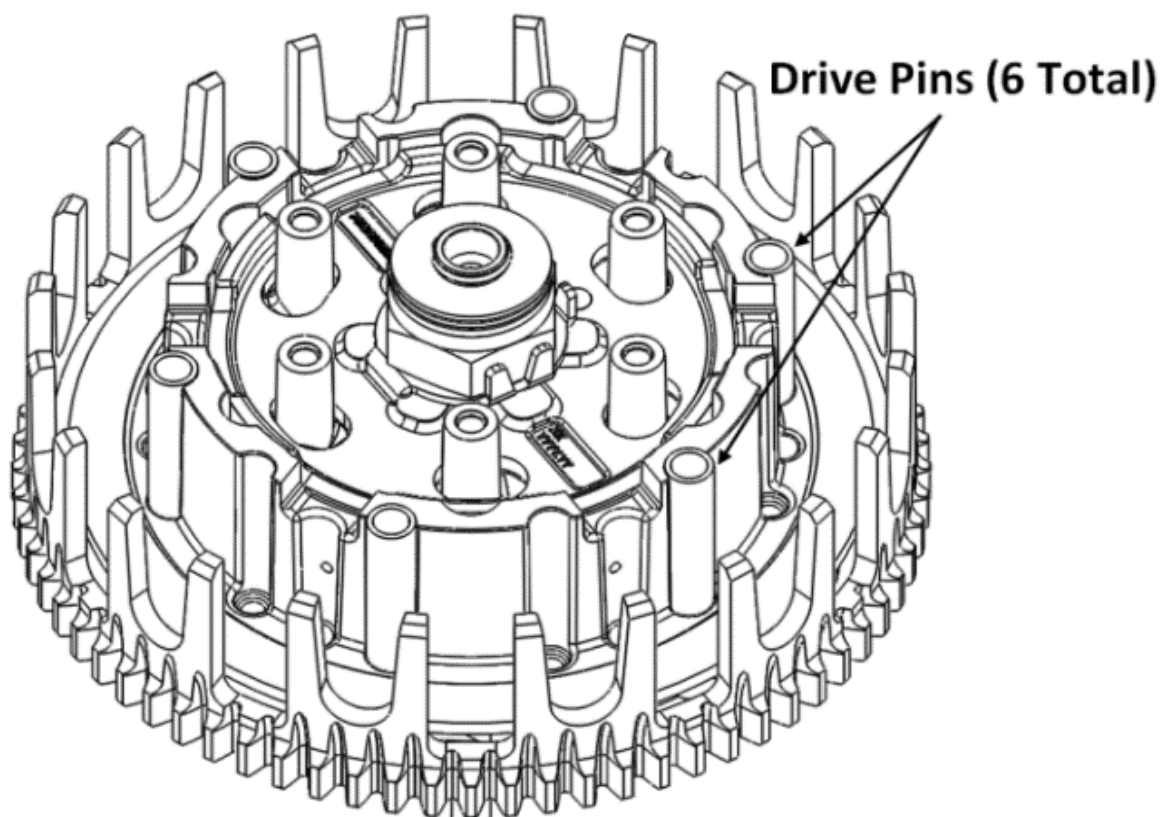

5. Check that the 6 OE drive pins are still seated into the Rekluse outer hub.

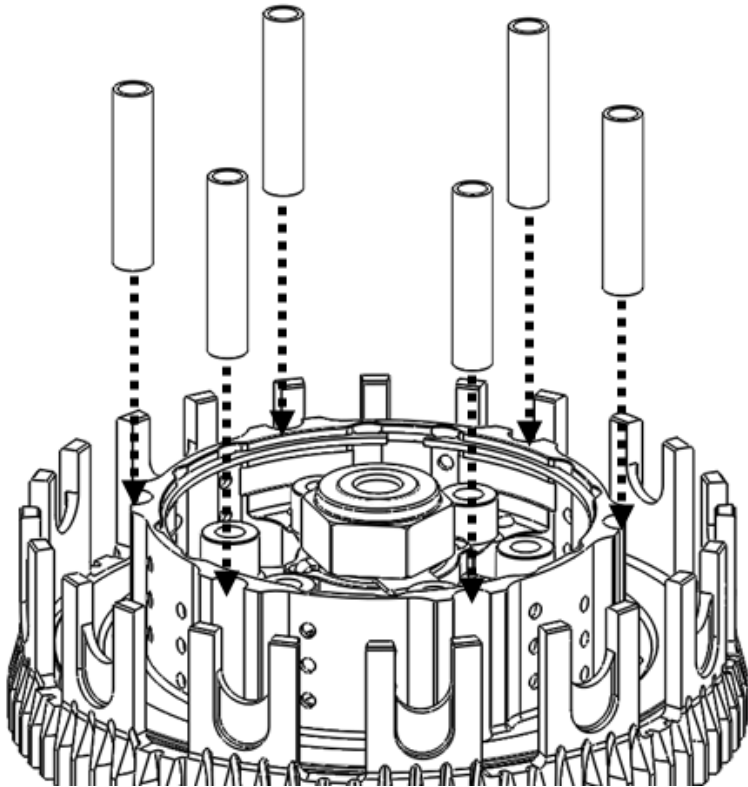

## INSPECT THE DAMPERS

The OE dampers inside the center hub assembly shrink due to heat and use. Any movement between the dampers will shorten the life of your clutch. Inspect the dampers before proceeding and replace if necessary. Use the following instructions to inspect the dampers.

1. Hold the center hub assembly in your hands, then place your thumbs on the inner hub by the embossed part numbers.



No Tools  
Required

2. Rotate the inner hub back and forth inside the outer hub.



### **NOTICE**

*Rekluse recommends replacing the dampers if you feel any play between the two hubs – KTM part number #78132025100.*



# CLUTCH PACK INSTALLATION

Each clutch pack comes with a set of steel plates, a set of friction disks, and an EXP disk. The specifics of the clutch pack depend on the bike. The height of the assembled clutch pack and specific information for each bike can be found on the Setup sheet.

1. Soak the friction disks and EXP disk in new oil for at least 5 minutes. Make sure the EXP and friction disks are coated on both sides.

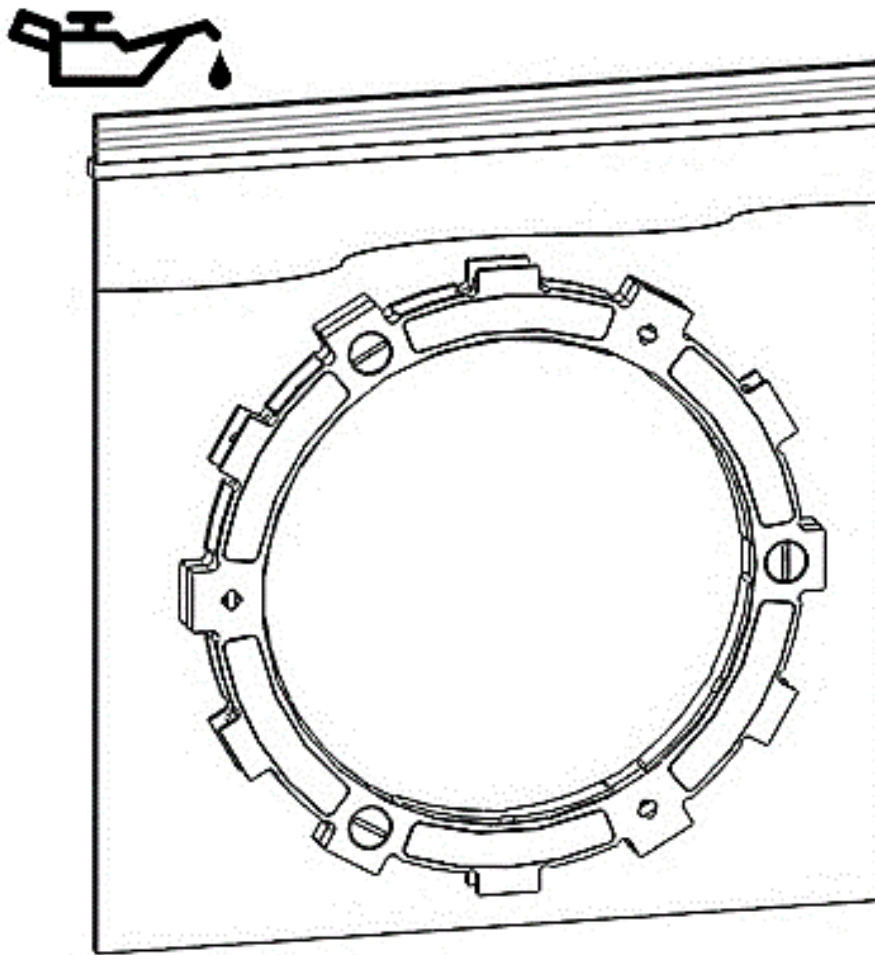

2. Install a steel TEC drive plate by first aligning the drive pin notches in the plate with the drive pins on the hub.



No Tools  
Required

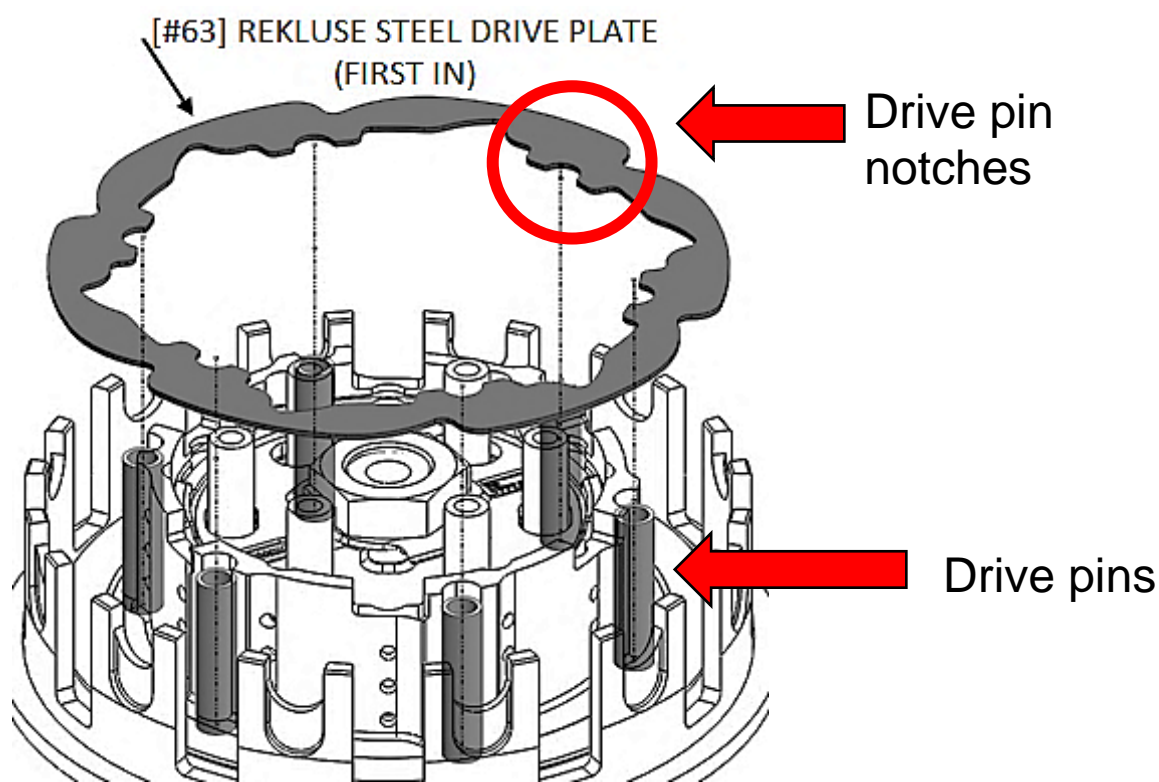

3. Place the steel plates in the orientation shown with the shark fin notches facing to the right. All drive plates will follow this orientation.

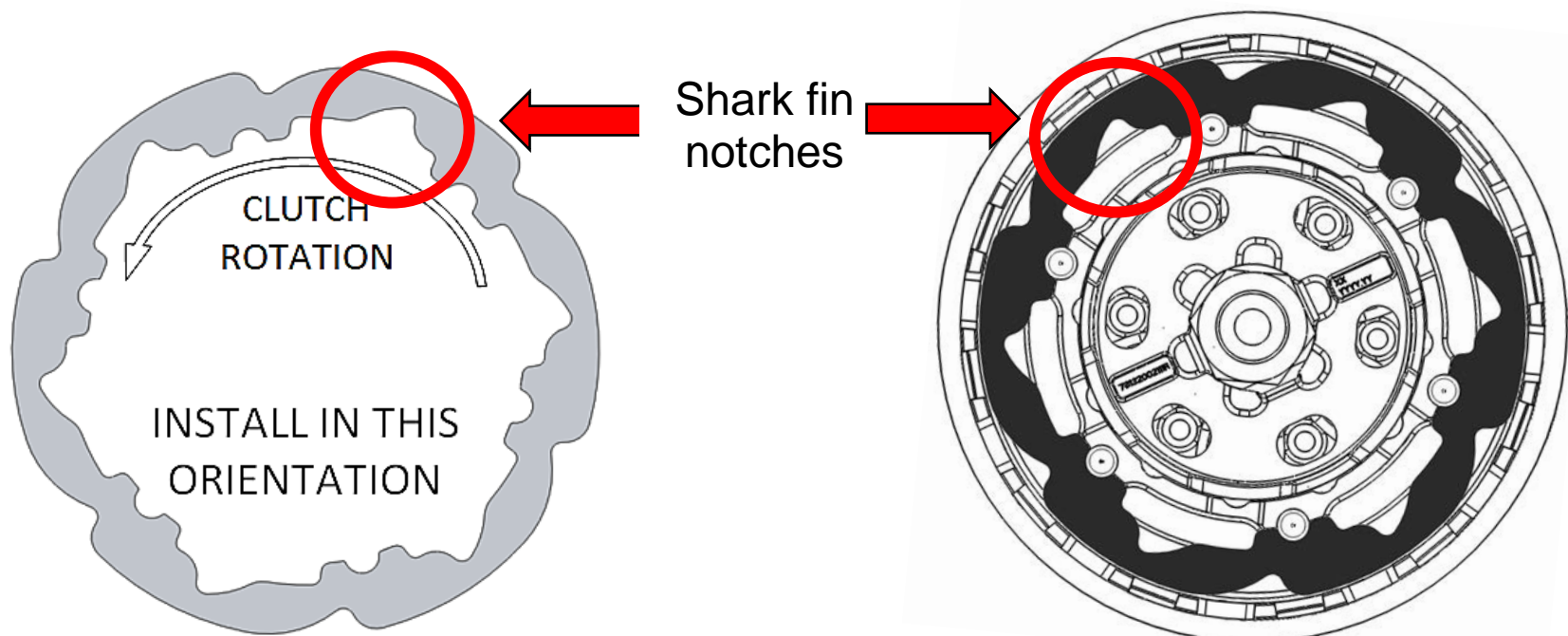

### NOTICE

*Proper orientation of the drive plates is critical for optimal clutch performance. If you install them backwards, the clutch will still function but will lack proper modulation performance.*

4. Add a friction disk on top of the steel drive plate. Some friction disks are marked with a small colored dot. This mark is used for processing and can be ignored.

5. Continue alternating the steel drive plates with the friction disks for the entire Rekluse clutch pack.

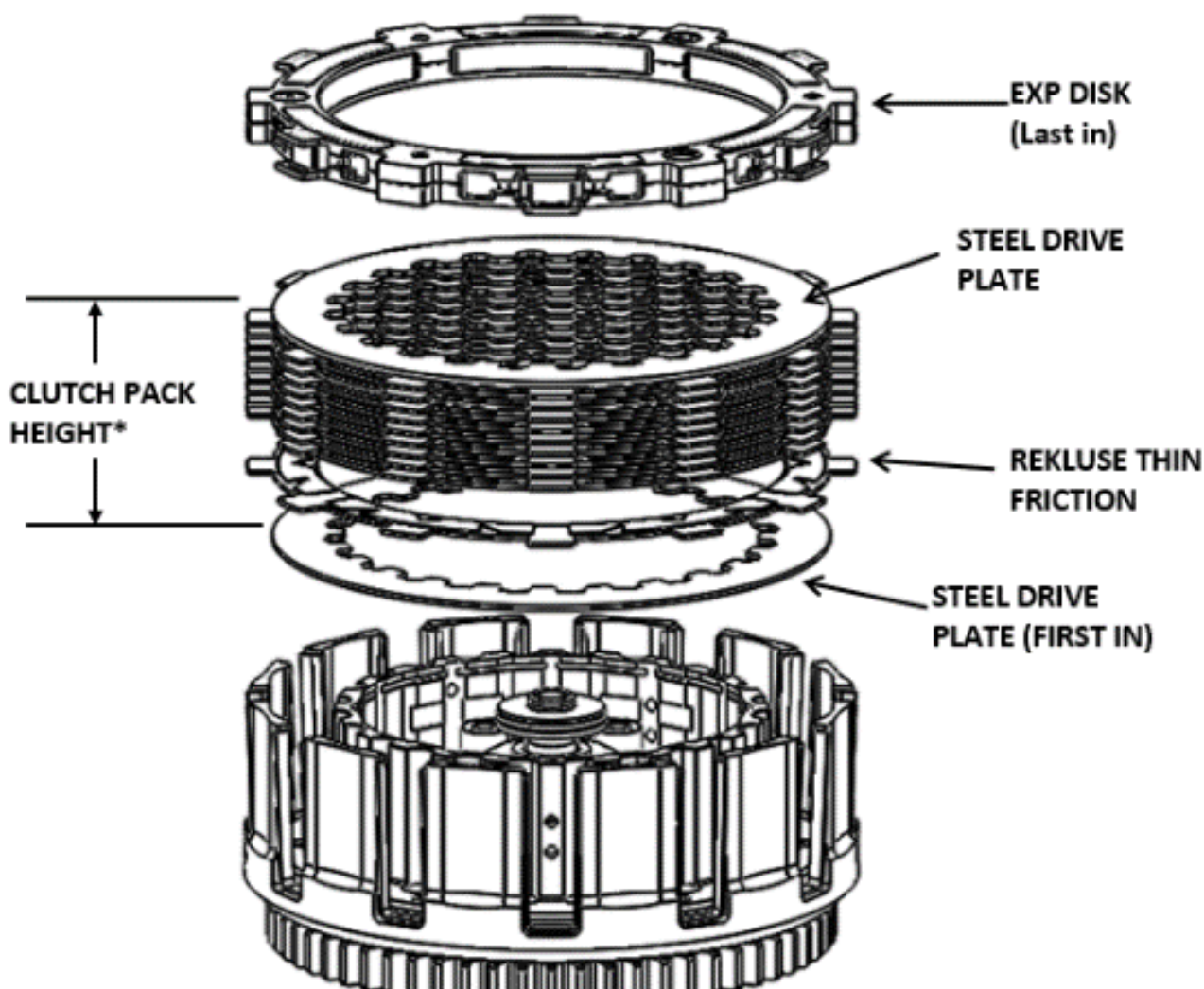

\*Refer to the Setup Sheet included with the clutch kit for the clutch pack height specifications.

6. Install the EXP disk on top of the last steel plate. Make sure that the EXP disk is seated in the same slots as the clutch pack.

### NOTICE

*Some OE basket have "half slots" at the top of the basket tangs. Rekluse products require that the entire clutch pack, including the EXP disk, be installed into the MAIN (deeper) basket slots.*

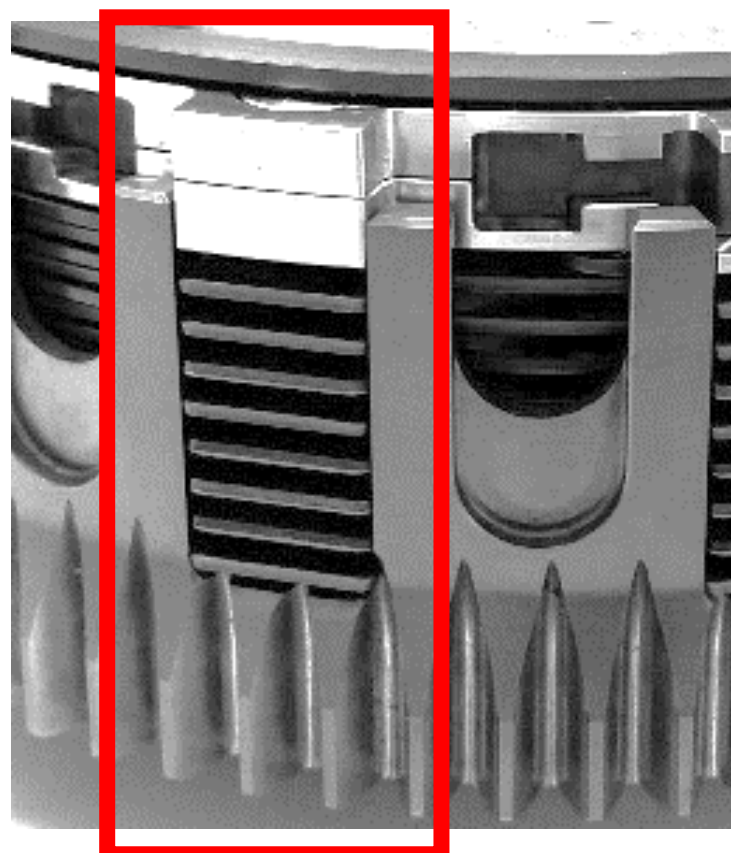

7. Check that the throw-out and thrust washer are still on the main shaft and not stuck to the bottom of the center hub assembly. Missing the thrust washer will cause clutch performance issues.

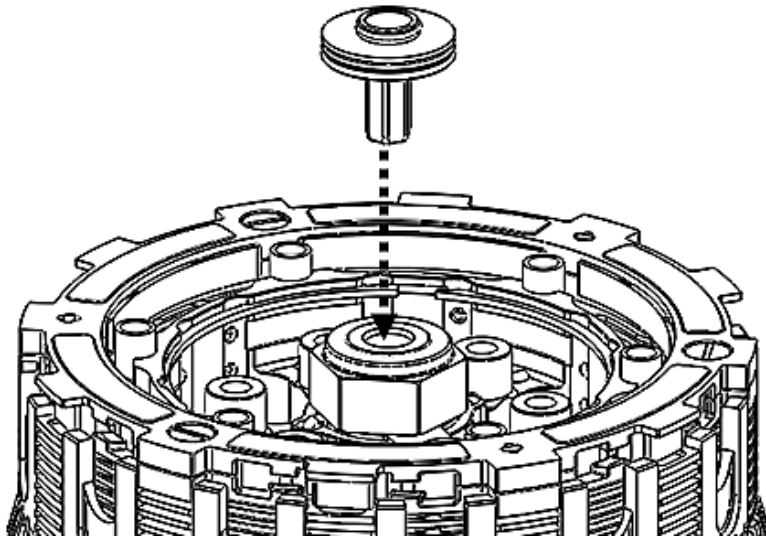

## PRESSURE PLATE INSTALLATION

1. Add a light film of oil between the lining plate and pressure plate. This will help the plates stick together for ease of installation.
2. Install the supplied lining plate onto the pressure plate by lining up the index tabs into the slots.



Oil



No Tools  
Required

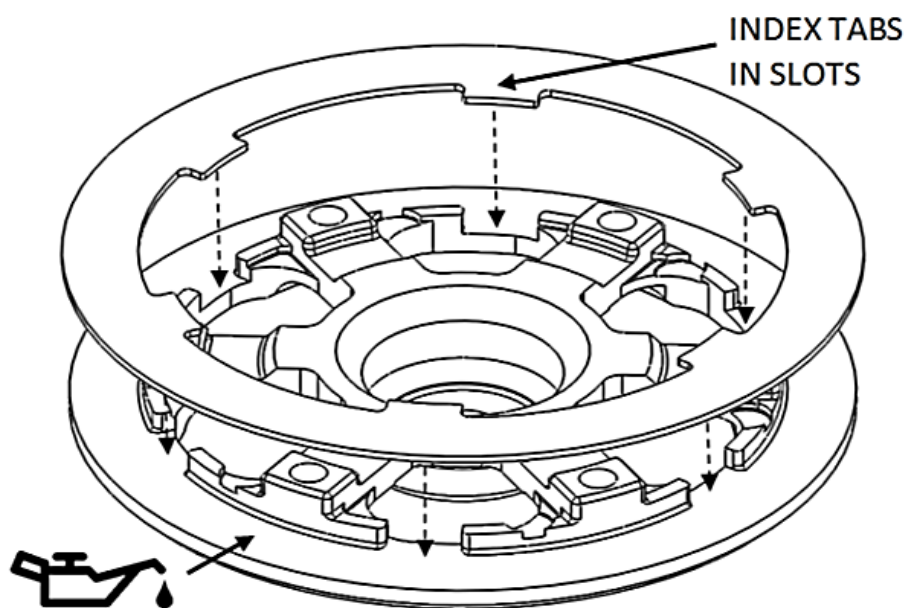

3. Install the pressure plate subassembly by lining up the index tabs on the pressure plate with the slots in the hub.



No Tools  
Required

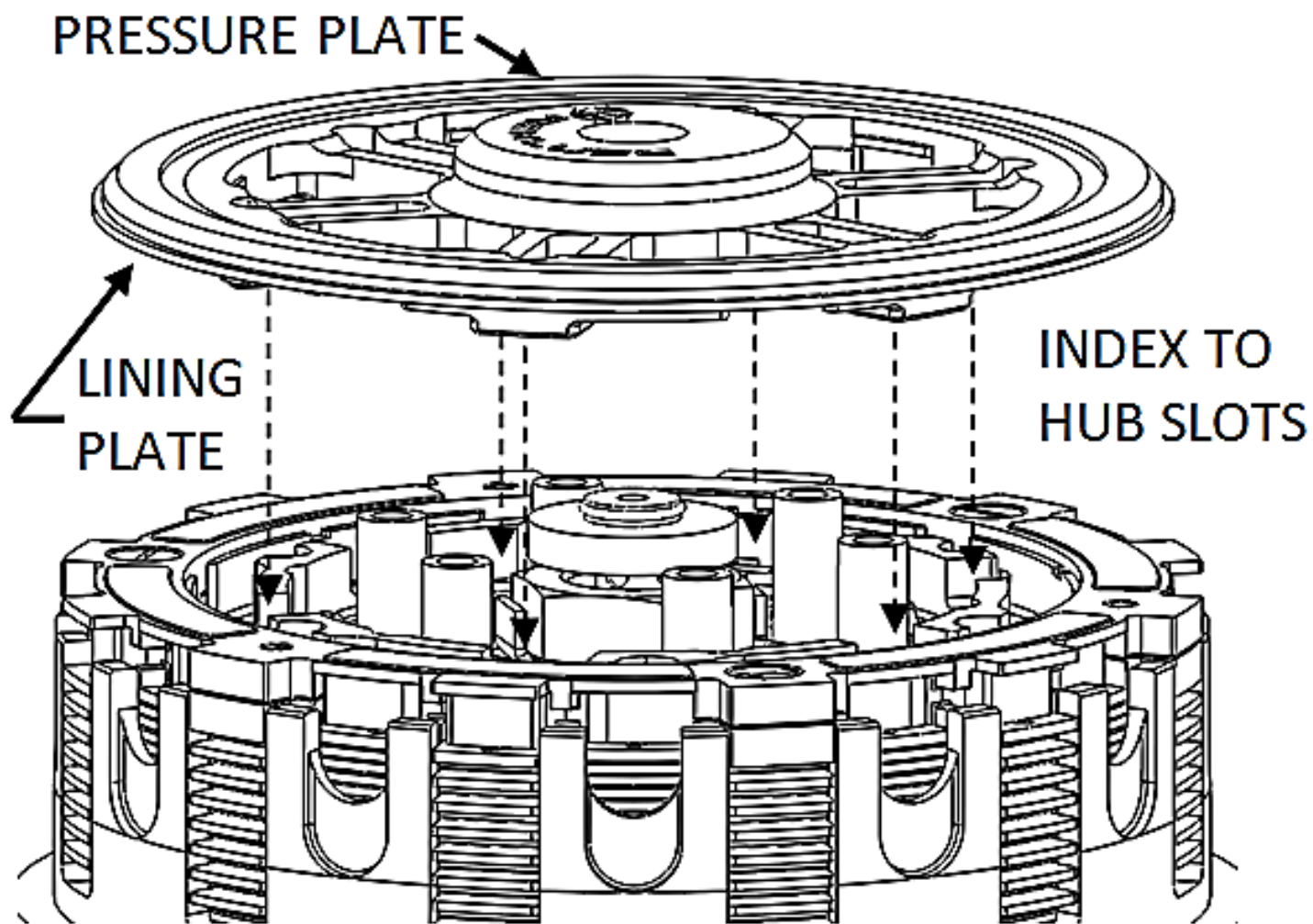

#### NOTICE

*When the pressure plate is seated correctly, the threaded standoffs will come through the openings of the pressure plate.*

4. Place the OE slider ring on the pressure plate with the “top” marking facing up. (The top side is rounded and the bottom edge is sharp.)

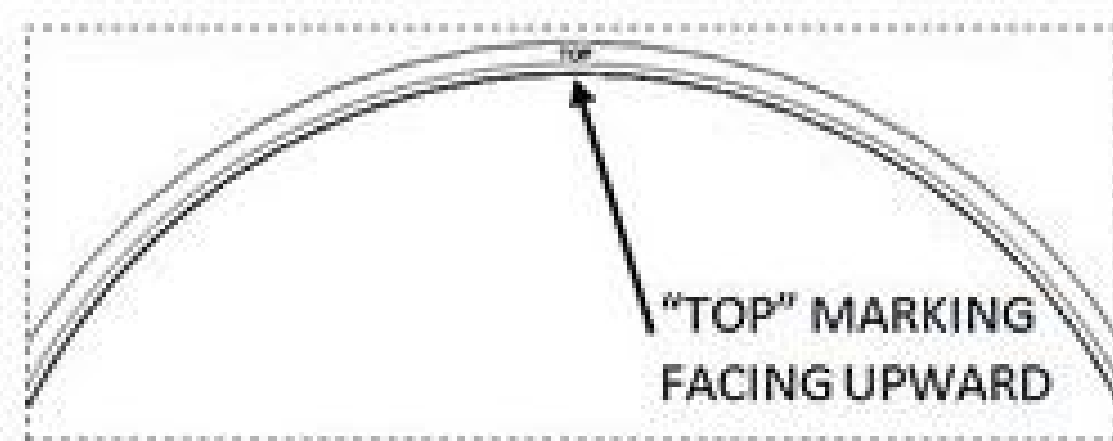

5. Place the OE Belleville spring onto the slider ring, with the rounded dome side facing up.

## NOTICE

*The outer edge of the Belleville spring will make contact with the Slider Ring. If it does not, the Belleville spring is upside down.*



Correct – The Belleville spring sits flat against the slider ring.



Incorrect – The Belleville spring is upside down.

6. Install the OE pressure ring, flat side up.

## NOTICE

*There are 3 possible settings on the OE Pressure Ring. Please refer to the setup sheet for optimized pressure ring setting. For a simple setting, set it to setting II (4-strokes and 2017 + 2-strokes) or X (pre 2017 2-strokes). In most cases, this is the best starting point for the clutch.*

7. Using the T-25 Torx bit and torque wrench, install the Rekluse pressure plate screws.



T-25 Torx Bit



Torque Wrench

**⚠ CAUTION**

***Do not reuse the OE screws, or clutch cover interference will occur!***

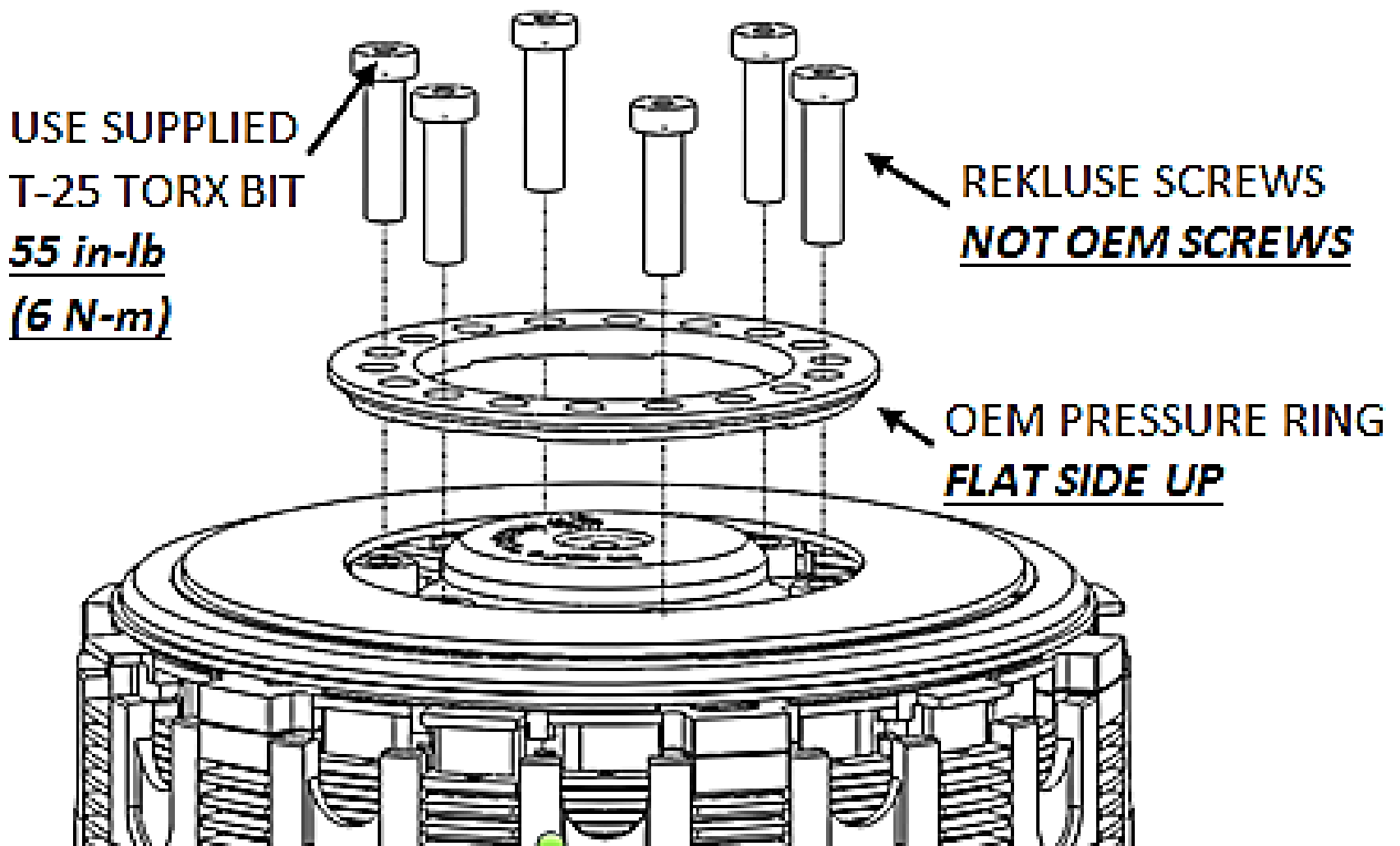

8. Remove the OE cover gasket from the OE clutch cover and install it onto the new Rekluse clutch cover.
9. Install the Rekluse clutch cover by lightly tighten the cover bolts in a star pattern. Tighten bolts in small increments before torquing the cover bolts to OE specifications. If your bike has an oil plug, transfer the OE oil plug to the new Rekluse clutch cover.

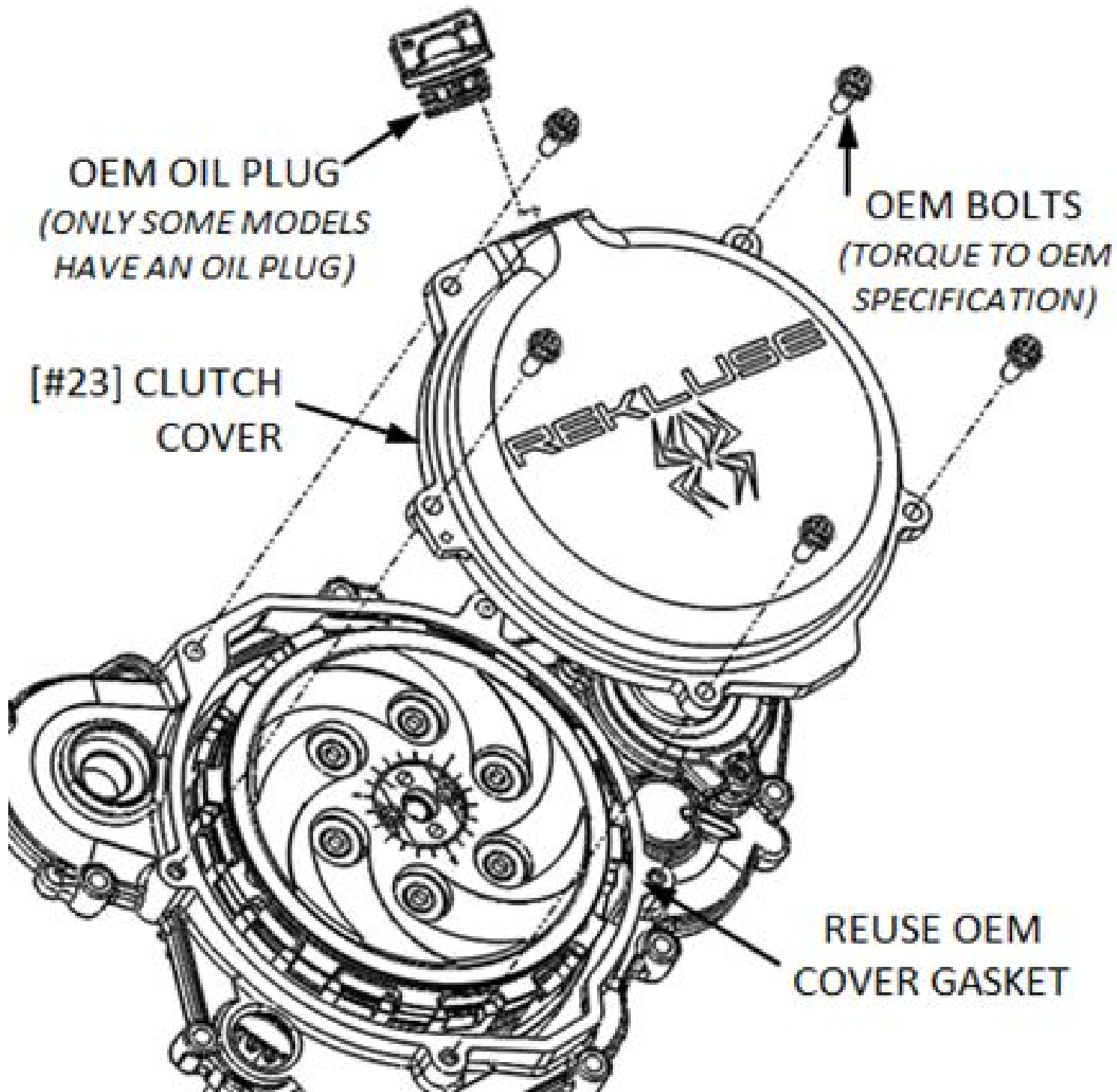



## SET THE INSTALLED GAP AND VERIFY BY CHECKING FREE PLAY GAIN

It is very important that you understand how to set the installed gap in your new clutch, and be able to verify the installed gap by checking Free Play Gain.

Setup, break-in, and rechecking the installed gap is **CRUCIAL**. Failure to properly maintain your installed gap can result in premature wear or failure of your clutch.

The “installed gap” is the free space in the clutch pack when the EXP disk is disengaged (collapsed). This gap allows the clutch to spin freely until the engagement RPM is reached and the EXP disk expands to close the gap and apply pressure to the pressure plate, which in turn drives the motorcycle forward.

The installed gap is what allows the auto function of the product to perform properly. Use the following steps to set the installed gap and check the Free Play Gain.

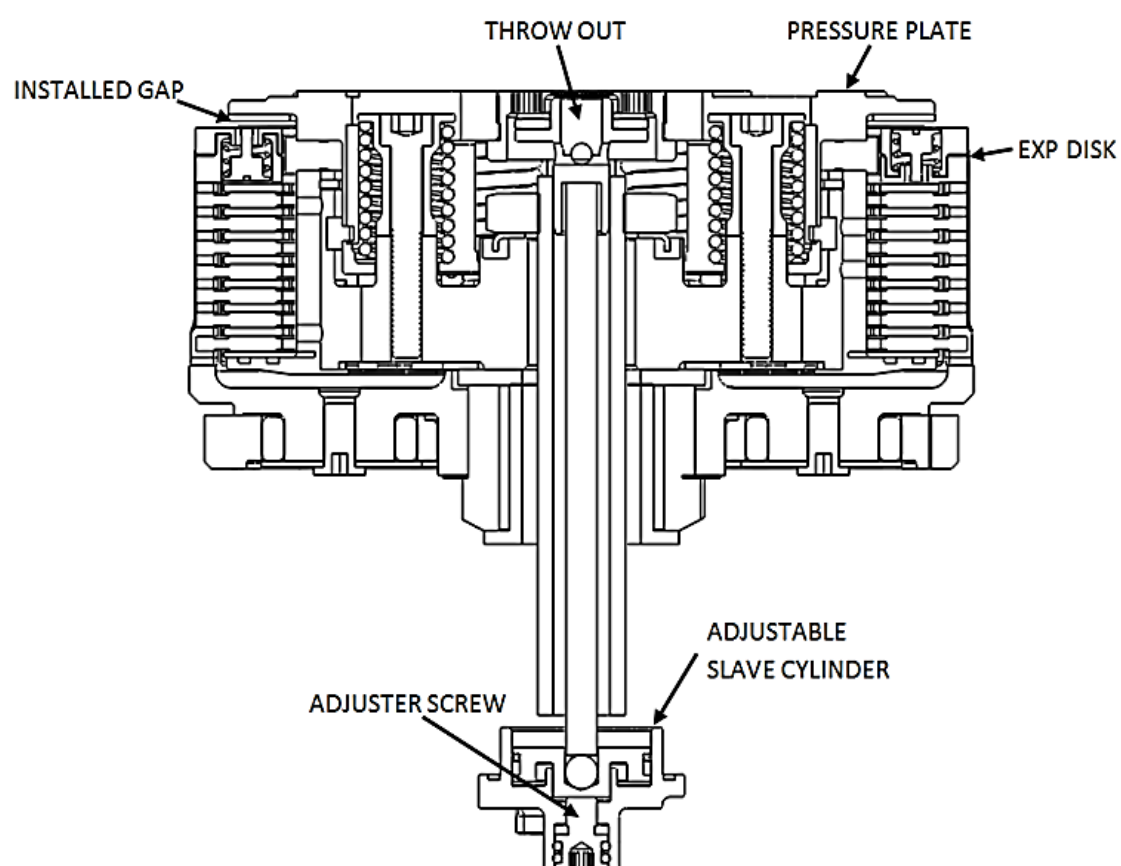

### **⚠ WARNING**

**Failure to check and verify Free Play Gain can cause failure or damage to this product. Setting the correct installed gap is critical for clutch performance.**

Setting the installed gap and checking Free Play Gain is a 4-step process. It is important to follow each step to ensure that your new clutch functions as designed.

## Step 1: Find the starting point

- a) With the bike standing up, locate the adjuster screw in the center of the adjustable slave cylinder.
- b) With the O-ring showing, use a 4 mm Allen wrench to turn the adjuster screw clockwise until it stops under light pressure. This is your “starting point.”

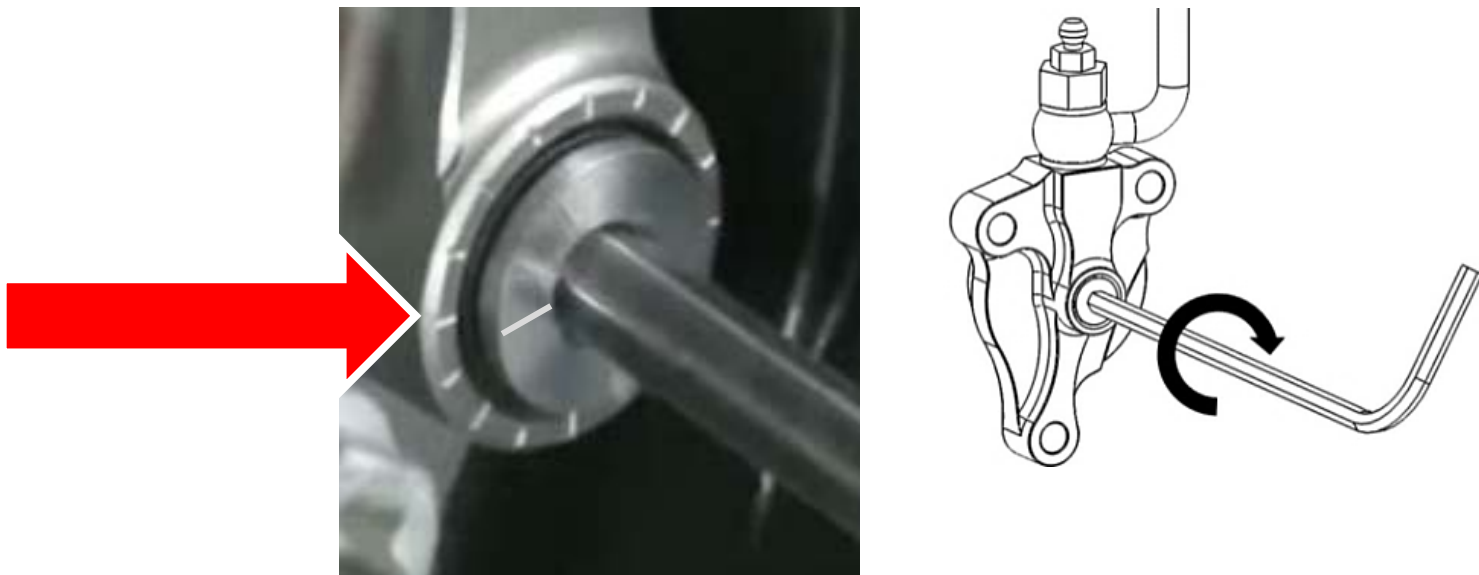

### NOTICE

*The resistance you feel is where the throw-out begins to lift the pressure plate. Finding the right starting point may take a few tries, but you will feel a noticeable change in turning effort once you reach that point. Stop when you feel the pressure increase. The “starting point” will change as the clutch pack wears overtime.*

- c) Once you have found the starting point, note the position of the Allen wrench using the tick marks on the slave cylinder housing and the small etch mark located on the screw. You will begin here to adjust the installed gap.

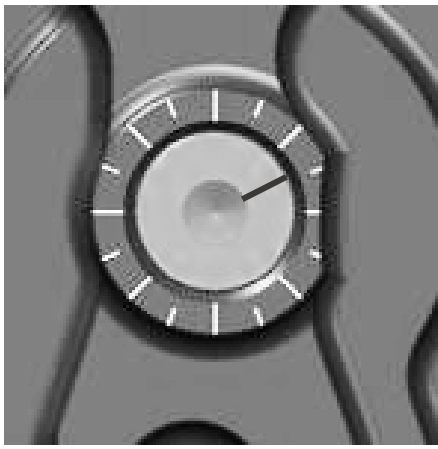

Use the tick marks on the cylinder and the etch mark on the screw to remember the starting point for adjusting the gap.

d) Use a 4 mm Allen wrench to turn the adjuster screw clockwise 1 full turn + 2 tick marks from your starting point. **This may NOT be your final setting**, but it is a beginning adjustment for finding the correct setting.

e) Continue with Step 2 to check for Free Play Gain.

### **⚠ CAUTION**

***Do not ride your bike without the adjusting the installed gap. You will not be able to disengage the clutch until you set the installed gap.***

## **Step 2: Learn how to check Free Play Gain**

Feeling Free Play Gain with the beginning adjustment to the slave cylinder aids in learning to recognize Free Play Gain.

If you are familiar with Free Play Gain, you can skip to Step 3 -“Break-in the new clutch.” If Free Play Gain is new to you, follow the instructions below to help you learn this important step. You can also view the video entitled “How to Check Free Play Gain” on our website at [www.rekluse.com/support/videos](http://www.rekluse.com/support/videos).

Free Play Gain is different from the “normal” free play you are used to with your stock clutch. With the Rekluse auto clutch, Free Play Gain is the result of the EXP disk expanding and lifting the pressure plate to engage the clutch.

Free Play Gain happens when the engine’s RPM increases from idle to above approximately 5,000 RPM and the EXP closes the

installed gap. The amount of Free Play Gain you feel in the lever corresponds to the amount the pressure plate has been lifted by the EXP disk expansion.

Checking Free Play Gain allows you to externally monitor the installed gap so you can know when to make an adjustment if the installed gap is too large or too small.

The correct installed gap is verified by observing and feeling the increased free play movement in the clutch lever. This extra movement is called “Free Play Gain.”

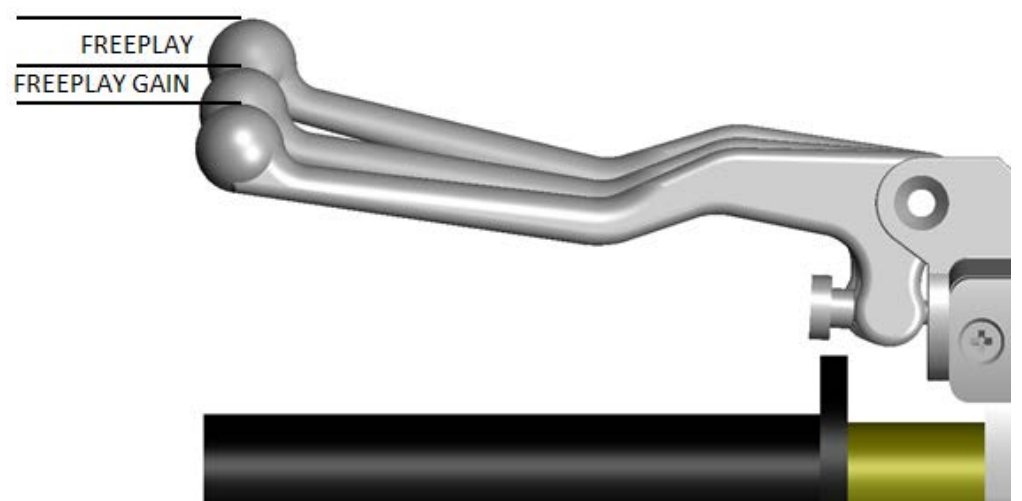

If there is too much Free Play Gain, the installed gap is too small. The bike may drag and stall because it has difficulty disengaging the clutch. It may also be difficult to shift. Too much Free Play Gain will not hurt the clutch, but it will negatively affect clutch performance.

With too little or no Free Play Gain, the installed gap is too large. This means when the EXP is fully expanded it does not lift the pressure plate. The clutch may slip and make the bike seem like it is losing power. The bike may not move forward even though the engine RPM increases as if the clutch lever is slightly pulled. Too little Free Play Gain will cause the clutch system to burn up.

Optimal Free Play Gain yields 1/8” (3 mm) of clutch lever movement, measured at the ball end of the lever. This measurement at the lever correlates to achieving the ideal installed gap.

## Two Ways to Check for Free Play Gain

The following steps explain **2 ways** to check Free Play Gain. One-way uses the rubber band Rekluse includes in the clutch kit, and one uses your hand. You can use either method to check for Free Play Gain.

Rekluse recommends that you begin with the rubber band method first to check for Free Play Gain and then learn the hand method. The rubber band will help you learn how to recognize Free Play Gain until you are comfortable with the hand method. Learning to check Free Play Gain by hand effectively and comfortably can make it easy to check Free Play Gain every time you ride.

### The Rubber Band Method

Use the rubber band method for the initial set up. It can also be used before each ride until you feel comfortable checking the Free Play Gain using the hand method.

#### **⚠ WARNING**

**BEFORE YOU BEGIN, verify that the bike is in NEUTRAL before checking Free Play Gain. Failure to do so may result in the bike lurching forward, and loss of control and/or injury may result.**

**A Rekluse auto-clutch can make your motorcycle appear to be in neutral when in gear, even when the engine is running and clutch lever released.**

**Motorcycles equipped with a Rekluse auto-clutch can move suddenly and unexpectedly and cause riders to lose control. To avoid death, serious injury, and/or property damage, always sit on the motorcycle to start it.**

- a) Before you begin, place the bike in **NEUTRAL**, start the engine and let it warm up for 2-3 minutes to idle down and warm the engine oil.

- b) Stretch the included rubber band between your thumbs, then place the top end of the rubber band on the outer end of the left handlebar grip.



- c) While holding the top end of the rubber band against the handlebar, stretch the band downward, then loop it through itself.



- d) Pull the band through the loop, then attach it to the outside end of the clutch lever. This will take up the initial free play (slack) and put the lever in a position to detect the Free Play Gain.



- e) While still in **NEUTRAL**, quickly rev the engine between 5,000-7,000 RPM (1/2 to 3/4 throttle), then let it return to idle. Notice the movement in the clutch lever when the engine is revved. This is your Free Play Gain.

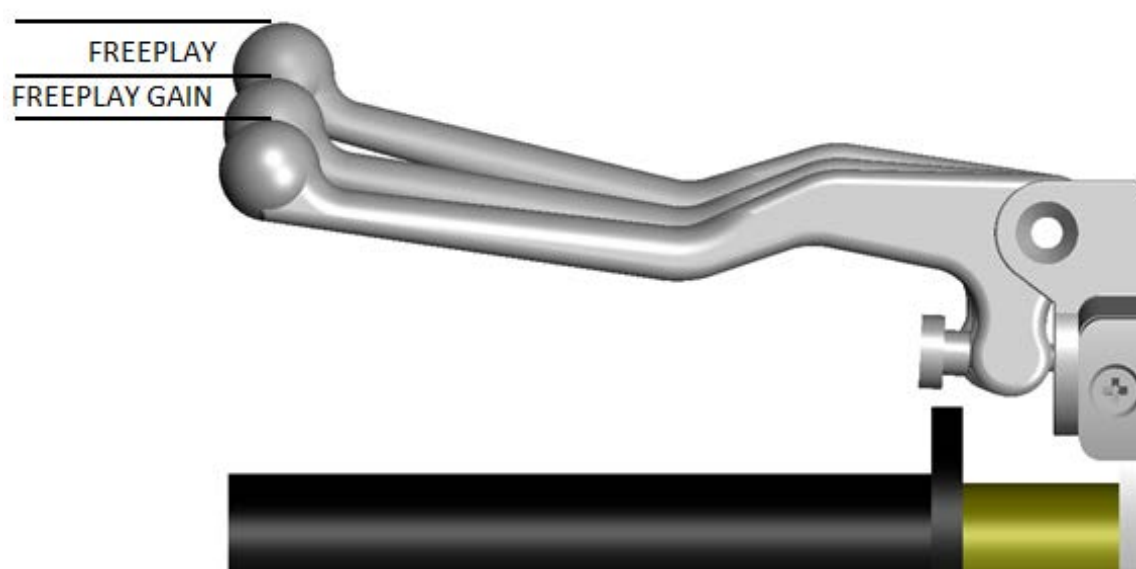

## NOTICE

*It is very important the motor returns to idle before revving the engine again or Free Play Gain will not be correct.*

- f) When the bike returns to idle, rest your hand across the clutch lever. Rev the engine again to 5,000-7,000 RPM so you can observe the movement while feeling for Free Play Gain with your hand.

## **The Hand Method**

Use the hand method to check Free Play Gain before the start of every ride for optimum performance and longevity of your new clutch.

### **⚠ WARNING**

**BEFORE YOU BEGIN, verify that the bike is in NEUTRAL before checking Free Play Gain. Failure to do so may result in the bike lurching forward, and loss of control and/or injury may result.**

**A Rekluse auto-clutch can make your motorcycle appear to be in neutral when in gear, even when the engine is running and clutch lever released.**

**Motorcycles equipped with a Rekluse auto-clutch can move suddenly and unexpectedly and cause riders to lose control. To avoid death, serious injury, and/or property damage, always sit on the motorcycle to start it.**

- a) Before you begin, place the bike in **NEUTRAL**, start the engine and let it warm up for 2-3 minutes to idle down and warm up the engine oil.



b) With the bike at idle, apply enough pressure to the clutch lever to take up the initial free play (slack) in the clutch lever.



c) While still in **NEUTRAL**, continue to apply light pressure and quickly rev the engine between 5,000-7,000 RPM (1/2 to 3/4 throttle), then let it return to idle. Notice the movement in the clutch lever when the engine is revved. This is your Free Play Gain.

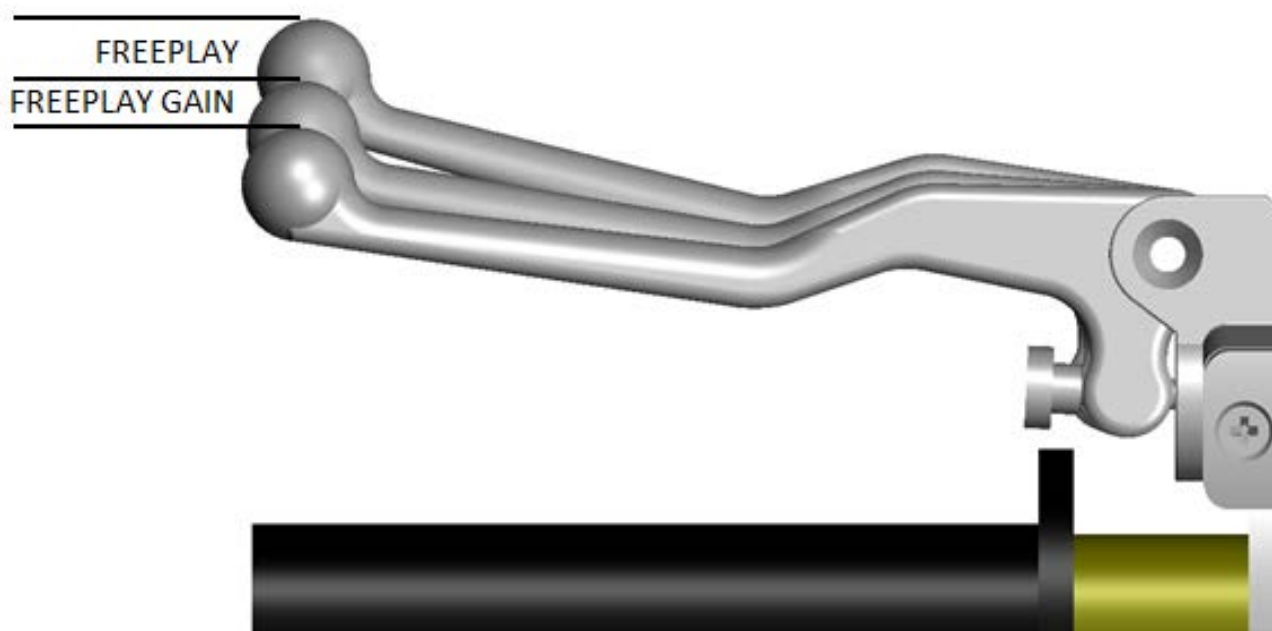

d) When the bike returns to idle, rev the engine between 5,000-7,000 RPM a second time to feel the Free Play Gain again.

e) Continue with Step 3 to break-in the new clutch.

## NOTICE

The lever may move more than 1/8" (3 mm) toward the handle when the engine is revved because there is too much Free Play Gain (movement of the clutch lever). This changes as you adjust the installed gap.

### Step 3: Break-in the new clutch

Once you install your new clutch, it is important to break it in. A series of roll-on starts are used to break in the clutch. Follow these procedures for breaking in your clutch and any time new friction disks, EXP bases, Teflon pads, or wedges are installed.

#### ⚠ WARNING

Failure to follow the break-in procedure and oil screen inspection process could cause motor oil delivery failure which can result in motor failure, serious injury, or death.

Break-in Procedure	Number of times
<p><b>Rev Cycles:</b></p> <ol style="list-style-type: none"><li>1. Place the bike in <b>NEUTRAL</b>.</li><li>2. With your hand <b>off</b> the clutch lever, rev the engine 10 times, being sure to let it <b>return to idle</b> between each rev cycle.</li></ol> <p>① <b>N</b> ② ③ ④ ⑤</p>	10 rev cycles

3. With the engine still running, pull in the clutch lever, then click the bike into 1<sup>st</sup> gear. Slowly release the clutch lever. The bike should stay in place or have a slight amount of forward creep.



4. With the bike idling in first gear, slowly apply throttle to begin moving.

5. Without using the clutch lever, accelerate moderately to approximately 5,000 RPM to fully lock up the clutch and come to a complete stop. Repeat 10 times.

10 roll-on starts

**NOTICE**

*If the engine wants to stall or the creep is excessive, the idle may be too high or the installed gap may be too small. Make necessary adjustments before proceeding.*

6. Without using the clutch lever, start in 2<sup>nd</sup> gear, then accelerate moderately to approximately 5,000 RPM and come to a complete stop. Repeat 10 times.



10 roll-on starts

7. Place the bike in **NEUTRAL** and recheck Free Play Gain.

8. Continue to step 4 to adjust the installed gap until the Free Play Gain of the clutch lever is 1/8" (3 mm).



Recheck Free Play Gain and adjust the installed gap

#### **NOTICE**

*Your clutch pack will expand with heat, so final adjustment to Free Play Gain should be made when the bike is warm. Remember not to ride without sufficient Free Play Gain.*

#### **CAUTION**

**Do not perform 3<sup>rd</sup> gear starts with this product. Starting in 3<sup>rd</sup> gear will burn up the clutch and decrease the performance of this product in a short amount of time.**

## **Step 4: Adjust the installed gap and Recheck Free Play Gain**

Once you have learned how to check Free Play Gain, you need to finish adjusting the installed gap, then recheck the Free Play Gain until the clutch lever moves only 1/8" (3 mm). The gap is adjusted by turning the slave cylinder screw.

- a) With the bike running and in **NEUTRAL**, locate the adjuster screw in the center of the adjustable slave cylinder.
- b) Use a 4 mm Allen wrench to turn the adjuster screw clockwise 1 tick mark from the last setting, then recheck Free Play Gain.



Tick marks are located on the slave cylinder, and an etch mark is on the screw. If you need to re-position the Allen wrench, you can use these marks for reference.

- c) Continue to adjust the slave cylinder 1 tick mark at a time until optimal Free Play Gain is achieved.
- d) Refer to the following pictures and chart in the next section for additional adjustment information.
- e) The Free Play Gain will change as the clutch pack wears over time.
- f) Checking the Free Play Gain is easy and indicates when the install gap needs adjusting.

# FREE PLAY GAIN ADJUSTMENTS

Make each adjustment in small increments - one tick mark at a time. After each adjustment, recheck Free Play Gain until you achieve the optimal 1/8" (3 mm) of clutch lever movement.



Symptom	Reason	Solution
<ul style="list-style-type: none"> <li>• Clutch lever moves in too far (too much Free Play Gain)</li> <li>• Clutch has excessive drag or stalls</li> <li>• It is difficult to fully override the clutch with the lever</li> </ul>	<p style="text-align: center;">Installed gap is too small</p>	<p style="text-align: center;">Turn the adjuster screw clockwise 1-2 marks to increase the installed gap and decrease Free Play Gain. Recheck Free Play Gain.</p>
<ul style="list-style-type: none"> <li>• Clutch lever only moves slightly or does not move at all (too little Free Play Gain)</li> <li>• Clutch slips</li> <li>• Bike seems to lose power</li> </ul>	<p style="text-align: center;">Installed gap is too large</p>	<p style="text-align: center;">Turn the adjuster screw counterclockwise 1-2 marks to reduce the installed gap and increase Free Play Gain. Recheck Free Play Gain.</p>

## MAINTENANCE

To keep your clutch performing at its best, perform regular maintenance on your bike and clutch.

- Keep up with regular oil changes as per the bike manufacturer's recommendations. Clutch performance and longevity depend on oil quality.

Oil recommendations can also be viewed under Tech Tips on our website at [www.rekluse.com/support/videos/atv-mc-support-videos](http://www.rekluse.com/support/videos/atv-mc-support-videos).

- Inspect all of your clutch parts for signs of wear or excessive heat, and replace components as necessary. Clutch wear is dependent on the riders use.

<b>Maintenance Protocol</b>	<b>Maintenance Intervals</b>
Check and verify Free Play Gain	Every ride
Inspect all clutch parts for excessive wear or heat. Replace as needed.	Refer to OE service manual

- The OE spring ring can be optimized based on the wear and height of the clutch pack. See the attached Setup Sheet for the spring ring optimization table to adjust the spring ring.
- Measuring the clutch pack and/or the EXP disk can help determine if the components need replacing. See the Setup Sheet for the specific clutch pack measurements.



Calipers

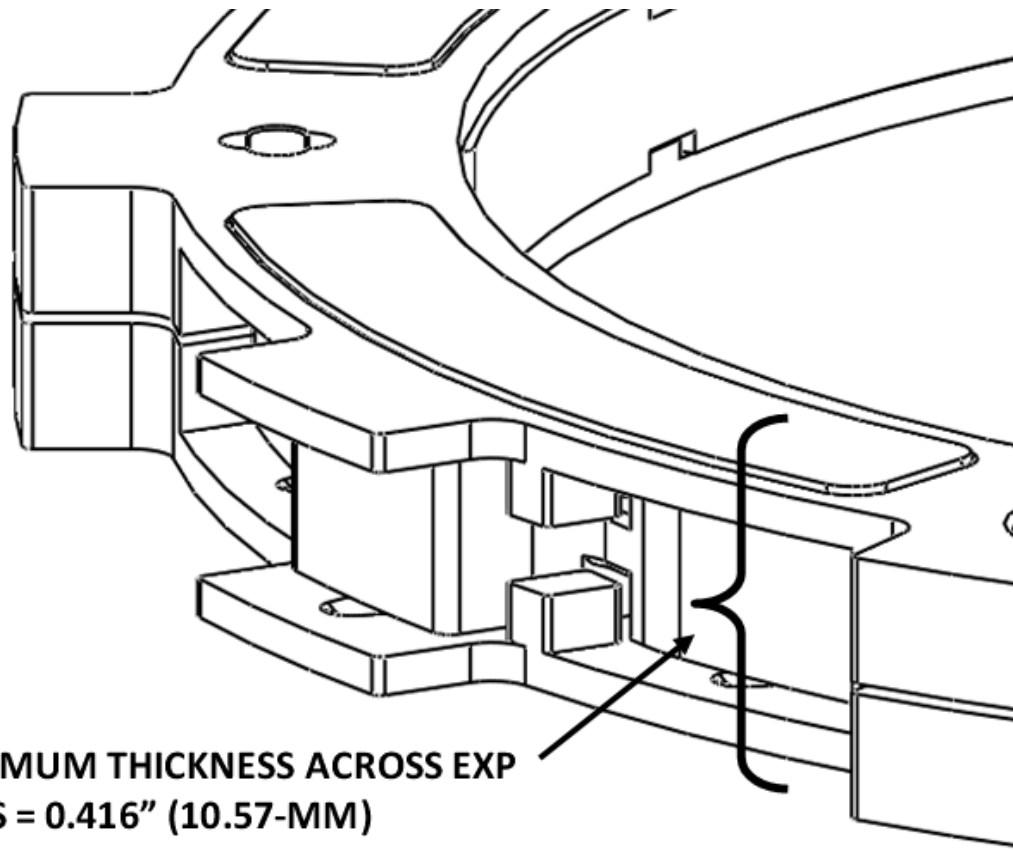

- Inspect the dampers, and replace them if you feel any movement between the two hubs. Refer to the section on inspecting the dampers for more information.
- Maintain adequate Free Play Gain. Check before every ride and adjust if necessary.
- Repeat the break-in procedure anytime you replace the EXP bases, Teflon pads, EXP wedges, or frictions disks. Always soak friction disks or EXP bases in oil for at least 5 minutes before installing.
- Replace friction disks if they measure below specifications listed on the attached Setup Sheet or if the disks are glazed and/or burnt.
- Replace the drive plates if they show signs of excessive heat.



## Disk inspection examples

When inspecting the clutch pack, the following pictures can be used as a reference. **These are best viewed in color by viewing this install document from [www.rekluse.com/support](http://www.rekluse.com/support).**

**Drive Plates** – If the clutch pack is getting high amounts of heat, purple, blue, or black color can be seen on the drive plate teeth. See pictures below. Not all drive plates look the same and may look different than pictured.

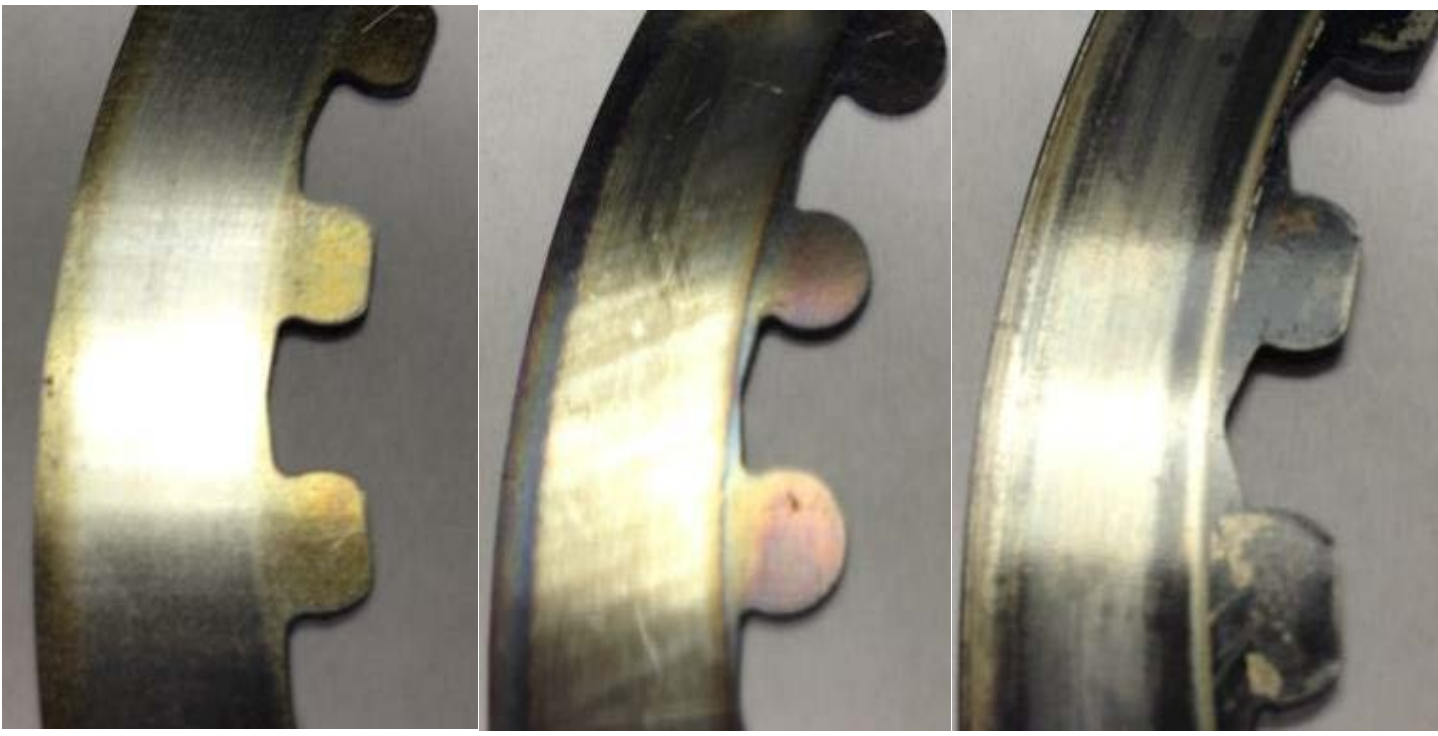

Normal Heat

High Heat  
(Blue)

Excessive Heat  
(Black)

**Friction Disks** – Due to the dark color of the friction material, the friction disks will appear almost black as soon as they are put in oil. During inspection, look for glazing of the friction material. Glazing will appear shiny and feel like glass, even after oil is cleaned from the friction disk. Not all friction disks look the same and may look different than pictured.



Normal  
Friction



Glazed  
Friction

# TROUBLESHOOTING

## **Performance issues**

If you find yourself adjusting the slave cylinder to fix Free Play Gain or drag, the clutch disks might be worn. Excessive heat or clutch slip can cause premature clutch failure as well. Once extreme temperatures are reached, irreversible damage will occur.

- Inspect all of your clutch parts for signs of wear or excessive heat, and replace components as necessary. Clutch wear is dependent on the riders use.
- Measuring the clutch pack and/or the EXP disk can help determine if the components need replacing. See the attached Setup Sheet for the specific clutch pack measurements.

## **Clutch noise**

Although it is harmless, some bike models may have “squeal” or “chatter” coming from the clutch at low RPM as it engages. Clutch squeal is caused by the clutch components vibrating as the clutch engages and can become more audible as the clutch gets hot. Adjusting the installed gap will NOT affect clutch squeal or chatter.

For bike models that have clutch squeal or chatter here are some recommendations to reduce or eliminate it:

- Change the oil: Rekluse recommends that you have fresh, clean JASO MA or JASO MA2 rated oil for best clutch performance. Dirty or old oil can make the clutch more likely to squeal or chatter.

## EXP TUNING OPTIONS

Adjusting the engine idle speed to match your engagement setting is important and greatly affects the overall feel of how the EXP disk engages. To prevent freewheeling and maximize engine braking,

set the idle so there is a slight amount of drag while the bike is idling in gear and warmed up. The idle should not be so high as to move the bike forward in gear with the throttle closed. However, with a small opening of the throttle the bike should move forward.

You can tune the engagement RPM of the EXP disk by changing the spring configuration. The EXP disk comes set with the recommended “**Medium**” setting from Rekluse. Use the following steps to change the springs. It is **NOT necessary** to disassemble the EXP halves to change springs!

## Changing the springs

1. Using a flat-blade screwdriver, push the ¼ turn pin in far enough to clear the opposite side of the EXP to unlock the pin.
2. With the pin still pushed past the base, turn 90° to remove the pin and spring.
3. Remove the remaining 2 pins and springs from the same side of the EXP base.
4. Drop a new spring into the spring slot on the base, then add the ¼ turn pin.
5. Push the turn pin in far enough to clear the base, then turn 90° and release the pin. The pin should sit almost flush with the EXP base.
6. Flip the EXP friction disk over, and repeat on the other side depending on engagement preference.
7. If you need to disassemble the EXP disk, you can watch the video on our website under Tech Tips at [www.rekluse.com/support/videos/atv-mc-support-videos](http://www.rekluse.com/support/videos/atv-mc-support-videos).

## NOTICE

To maintain even pressure, when using two different color spring sets, install one set of 3 on one side of the EXP and the remaining set of 3 on the other side.

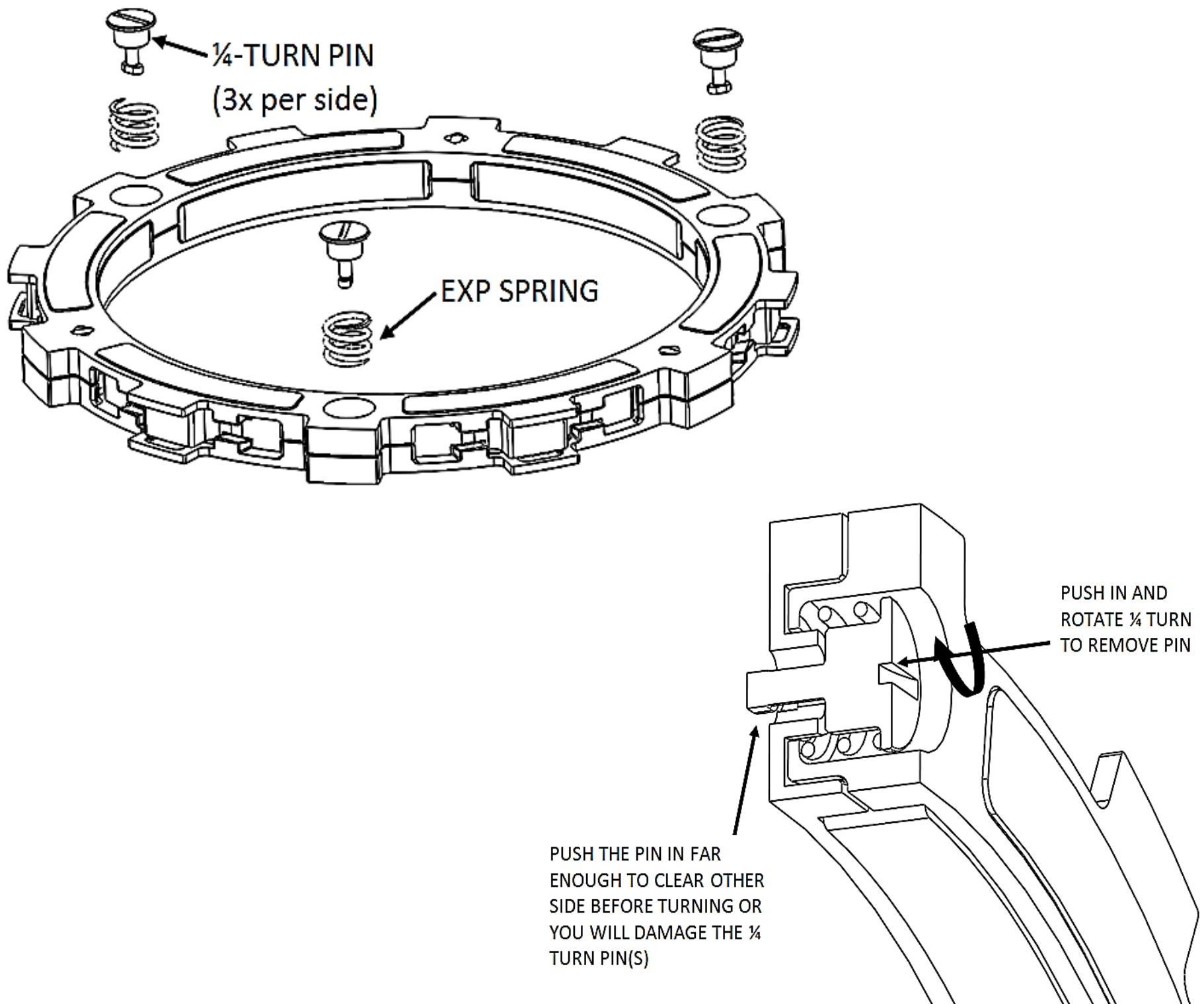

## CAUTION

**If you disassemble the EXP, the Teflon pads may fall out or be stuck to the ramp surfaces of the EXP bases. Take care to ensure all pads are correctly placed into wedge pockets using gentle pressure to avoid damage to the pad surfaces before reassembling the EXP. Properly seated pads will be secured in place once the EXP is reassembled. Operating the clutch without the pads in place will cause part damage or failure.**

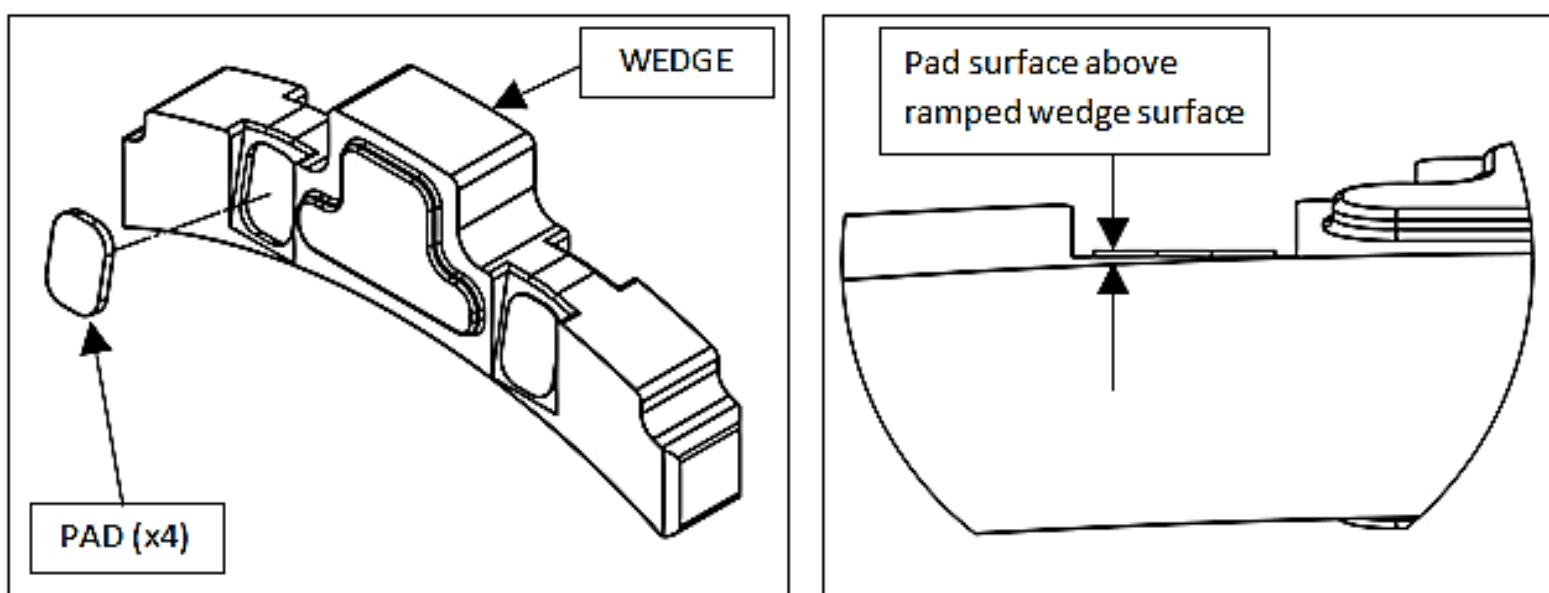

## Configuration chart

ENGAGEMENT SETTING	SPRING CONFIGURATION			
	<b>450/500/501 4-stroke</b>	<b>250/300 2-stroke (Pre 2017)</b>	<b>250/300 2-stroke (2017+)</b>	<b>250/350 EXC-F/ XCF-W</b>
<b>Low</b>	6 Blue	6 Silver	6 Steel	6 Silver
<b>Medium</b>	3 Blue & 3 Gold	3 Silver & 3 Red	3 Silver & 3 Steel	3 Silver & 3 Red
<b>High</b>	6 Gold	6 Red	6 Silver	6 Red

## BUMP-STARTING THE BIKE

If your bike needs to be bump-started due to a dead battery or any other reason, follow the steps below to quickly bump-start your bike.

1. Turn the adjustable slave cylinder counterclockwise to collapse the gap until no resistance is felt.
2. Bump start the bike. The clutch will function like a manual clutch at this point, but the clutch will not be fully over-rideable at high RPMs.
3. Once the bike is started, readjust the installed gap.

## NEED ADDITIONAL HELP?

### Website

[www.rekluse.com/support](http://www.rekluse.com/support)

### Frequently asked questions

[www.rekluse.com/faq](http://www.rekluse.com/faq)

### Support Videos

[www.rekluse.com/support/videos](http://www.rekluse.com/support/videos)

### Phone

(208) 426-0659

### Technical Support

Contact Technical Support for questions related to product installation, tuning, and performance.

#### Technical Support hours:

Monday, Tuesday, Wednesday, and Friday: 8:00 a.m. - 5:00 p.m.

Thursday: 8:00 a.m. – 4:30 p.m.

Mountain Time zone

Email: [tech@rekluse.com](mailto:tech@rekluse.com)

### Customer Service

Contact Customer Service for additional product information, orders, and returns.

#### Customer Service hours:

Monday, Tuesday, Wednesday, and Friday: 8:00 a.m. - 5:00 p.m.

Thursday: 8:00 a.m. – 4:30 p.m.

Mountain Time zone

Email: [customerservice@rekluse.com](mailto:customerservice@rekluse.com)